



YOSHIMURA

RESEARCH&DEVELOPMENT OF AMERICA, INC.

5420 DANIELS STREET STE A, CHINO CA., 91710 · (800) 634-9166 · (909) 628-4722 · FAX (909) 591-2198

www.yoshimura-rd.com

FENDER ELIMINATOR KIT

070BG121220
Honda Grom



THIS PRODUCT IS NOT DOT APPROVED.

Yoshimura R&D of America, Inc. is not liable or responsible for any resulting event caused by the installation of this product. Check with local laws and regulations for compliance prior to installation and use. This product is not intended for use on public highways.



Assembly Diagram

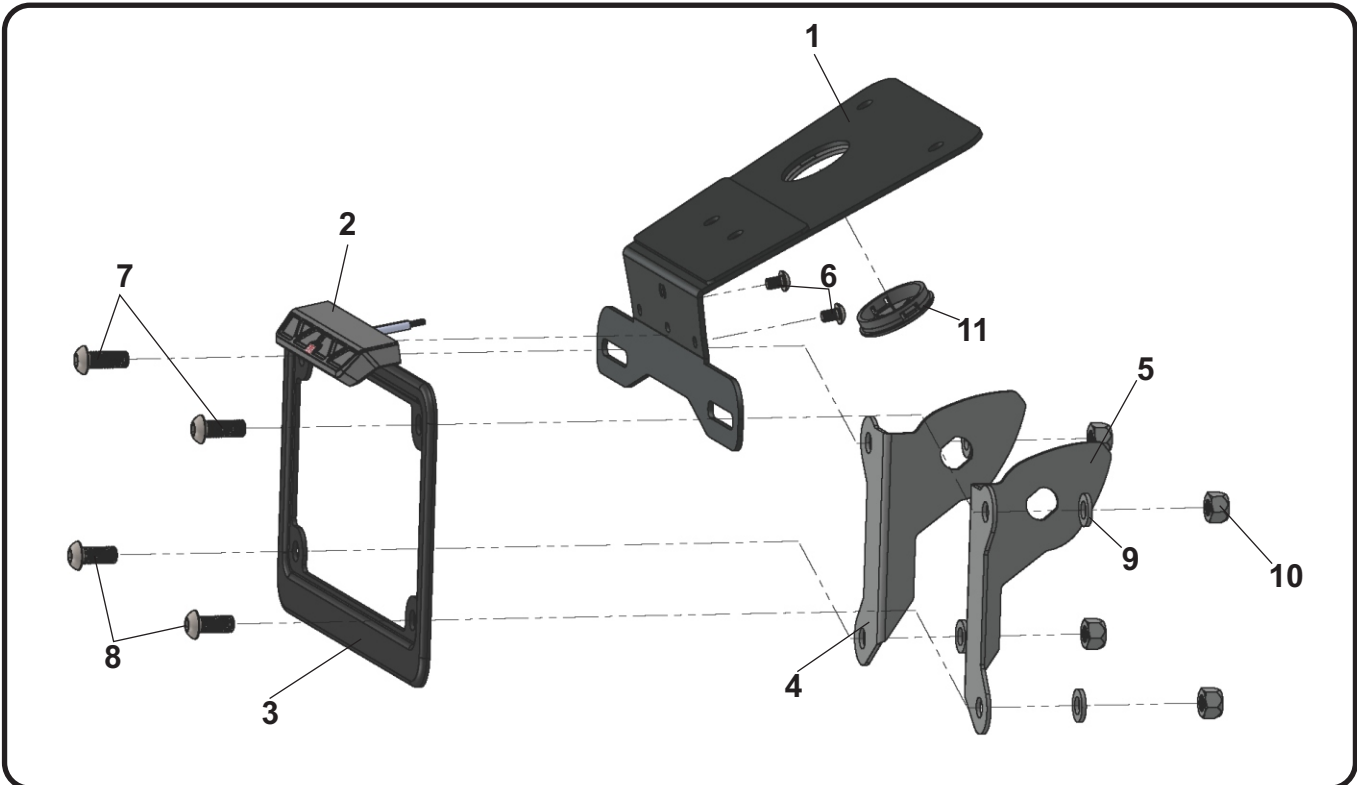

No.	Item	Description	Qty.
1	12122-FEBKT	Fender Eliminator Bracket	1
2	070BG-LH-K1	LED License Plate Light	1
3	070BG-LPF	License Plate Frame	1
4	12122-TSB-L	Left Turn Signal Bracket	1
5	12122-TSB-R	Right Turn Signal Bracket	1
6	M4X6BHS	4mm x 6mm Button Head Screw	2
7	M6X16BHS	6mm x 16mm Button Head Screw	2
8	M6X14BHS	6mm x 14mm Button Head Screw	2
9	6MMWASHER	6mm Washer	8
10	6MMLN	6mm Nylon Lock Nut	8
11	H-2158	Dust Cover	1
**	BN-SSS-22-18	Solder Shrink Connectors	2
**	ZT-400	Cable Ties	1
**	17100	Yoshimura Sticker Sheet	1

Optional Parts

070BGUNVTBKT	Universal Turn Signal Bracket Kit	070BG12121TSBKT	High Mount Turn Signal Bracket Kit
072BGLTSFK	Yoshimura LED Turn Signal Kit	072BGLTSFK-S	Yoshimura Sequential LED Turn Signal Kit
072BGLTSR	Yoshimura LED Turn Signal Kit w/ Relay	072BGLTSR-S	Yoshimura Sequential LED Turn Signal Kit w/ Relay
073BG-HON-2	Plug 'n Play Turn Signal Adapter Wire, Front	073BG-HON-1	Plug 'n Play Turn Signal Adapter Wire, Rear

** Not shown on diagram.

Removal

1. Remove rider seat.
2. Locate and disconnect the stock license plate light and turn signal connectors.
3. While securely supporting the stock fender assembly, remove the four fender bolts securing the fender assembly to the subframe. Carefully remove the stock fender assembly making sure not to damage connectors in the process.
4. Disassemble the stock fender assembly and remove left and right turn signals.
5. Cut the license plate light connector from the stock fender assembly. Be sure to cut wire at least 2" from the bulb.

Installation

1. Install (No. 11) *H-2158*, dust cover onto (No. 1) *12122-FEBKT*, fender eliminator bracket. To ensure best fit, line the tabs on the dust bracket with the tabs cutouts on the bracket.

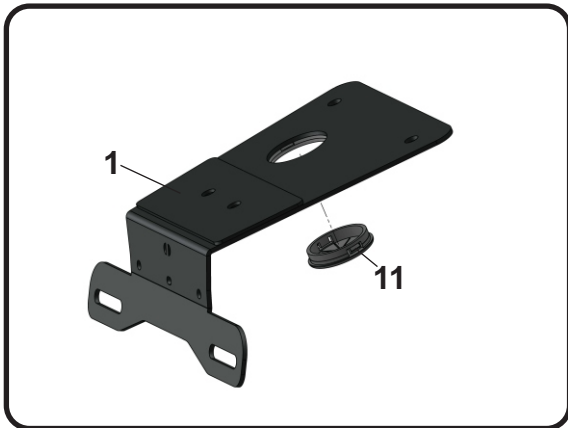

2. Install (No. 2) *070BG-LH-K1*, LED license plate light onto (No. 1) *12122-FEBKT*, fender eliminator bracket using (No. 6) *M4X6BHS*, 4mm screws.

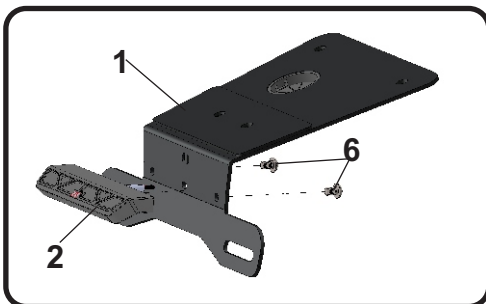

3. Using the *BN-SSS-22-18* solder shrink connectors provided in the kit, connect the Yoshimura license plate light wires to the stock license plate light wires as follows:

Red -to- Yellow
Black -to- Green

- a) Strip the stock fender light wire ends 1/4" - 1/2" and insert into *BN-SSS-22-18*, solder connectors provided in the kit.
- b) Center the spliced wire ends in the middle and using a heatgun or lighter, apply heat evenly on the outer edges of the butt connector to shrink and hold wires in place.
- c) Making sure that the stripped ends are centered, heat the center of the butt connector evenly until the solder begins to liquify.
- d) Allow to cool completely and tug both ends of the wires to verify that connection is secured.

Scan for link to solder shrink connector instruction video.



4. Install the stock rear turn signals onto (No. 4,5) *12122-TSB-L/R*, left and right turn signal brackets using the stock hardware.
5. Assemble and install (No. 4,5) *12122-TSB-L/R*, left and right turn signal brackets and (No. 3) *070BG-LPF*, license plate frame to (No. 1) *12122-FEBKT*, fender eliminator bracket using the (No. 7,8) *M6X16BHS* and *M6X14BHS*, 6mm button head screws and (No. 9,10) *6MMWASHER*, *6MMLN*, washer and nut as shown.

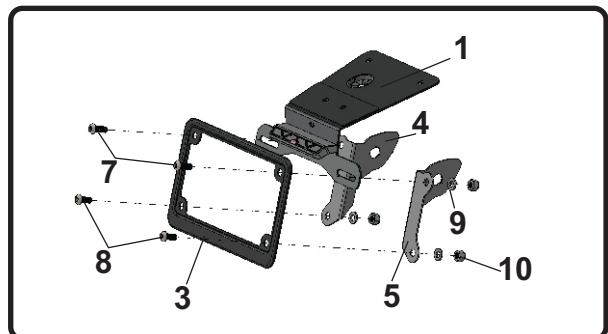

- Route license plate light and turn signal wires through the hole in (No. 11) *H-2158*, dust cover and through the lower rear cowl. Secure (No. 1) *12122-FEBKT*, fender eliminator bracket to subframe using the four stock fender bolts and (No. 9,10) *6MMWASHER*, *6MMLN*, washer and nut as shown.

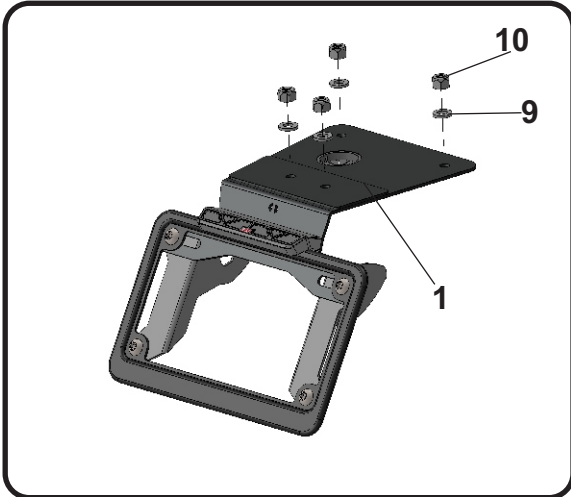

- Use the cable ties supplied in the kit to secure license plate light and turn signal wires to fender bracket.

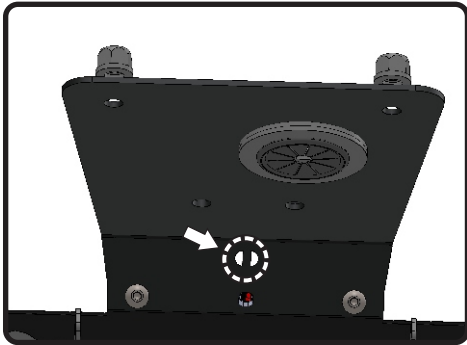

- Re-connect license plate light and turn signal connectors.
- Re-install rider seat.
- Check for proper function of license plate light and turn signals and that all brackets and components are secure prior to riding.